



Instruction

# Disassembling and assembling PAHT and PAHT G 50-90



Table of Contents

Contents

1. Introduction	2
2. Disassembling the pump	3
3. Inspection	9
Valve and thrust plate	9
Valve and thrust plate	9
Swash plate	9
Pistons	9
4. Assembly	10
5. Spare parts list for PAHT 50-90	18
6. Spare parts list for PAHT G 50-90	19
9. Tool sets	20

1. Introduction

**NOTE: If the pump is disassembled within the warranty period, the pump is no longer covered by the warranty.**

Tools required for dismantling the pump



2. Disassembling the pump





7. Turn pump upside down.



8. Loosen and remove 10 screws.



9. Remove cover.



10. Remove pistons and retainer plate.



11. Remove retainer ball

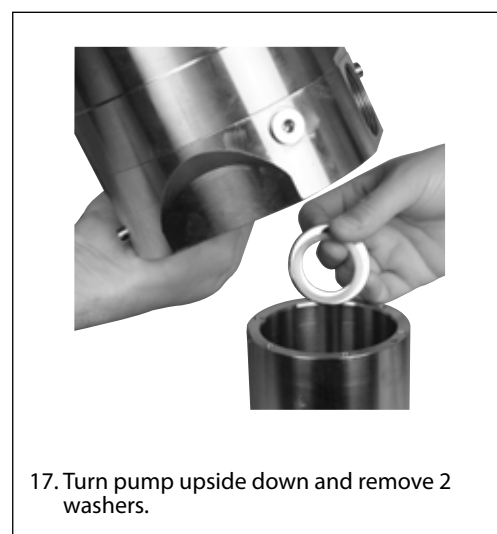
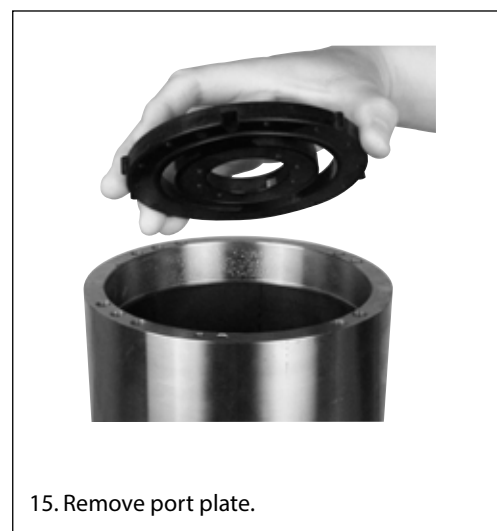

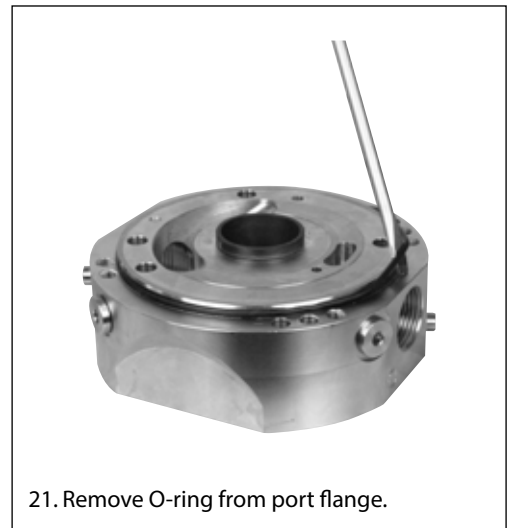



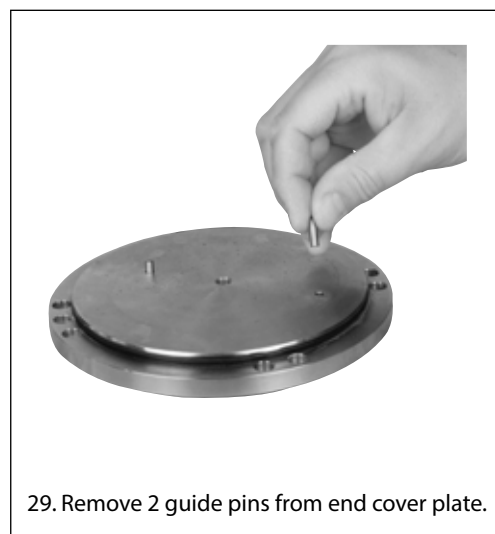
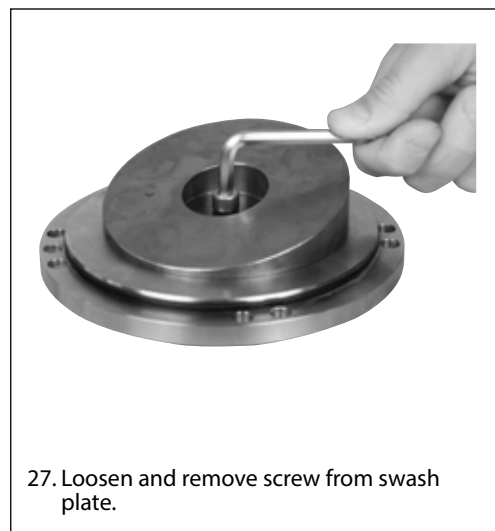
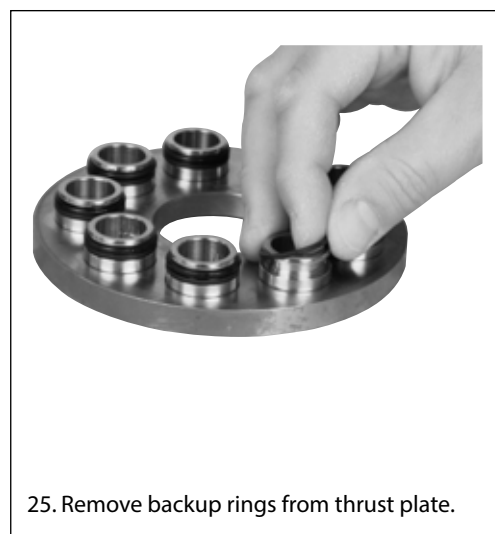
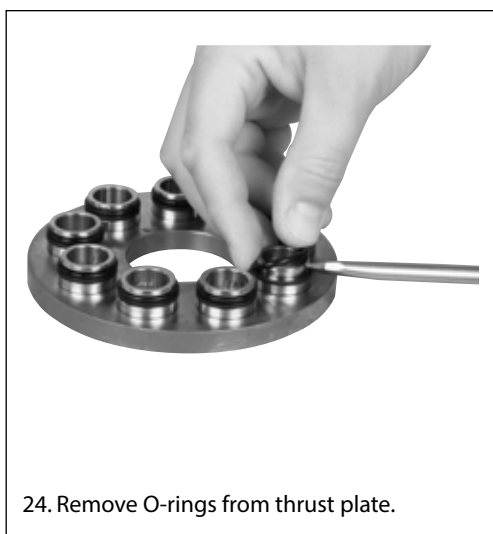

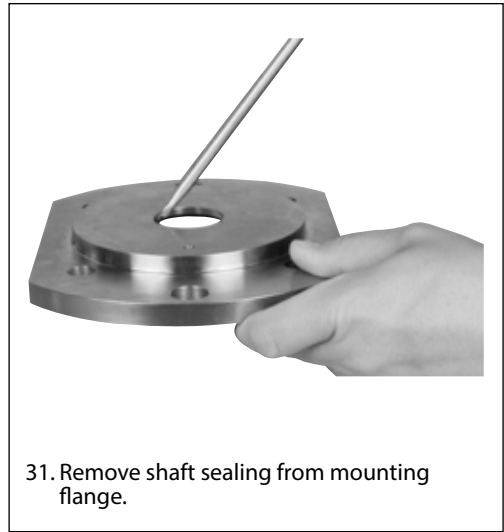



3. Inspection

Valve and thrust plate

Valve and thrust plate

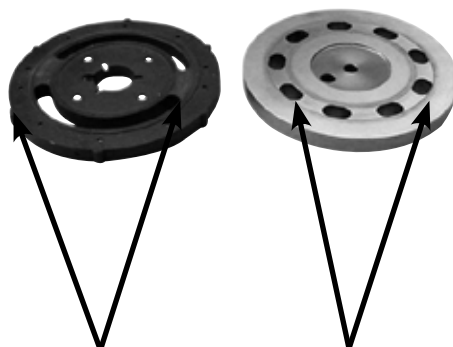

1. Neither valve plate nor thrust plate must show any sign of wear.



2. Hold a ruler against surface of plate and check tightness against a light source.  
3. Check that both O-rings and back-up rings are not broken and do not show severe wear.

Swash plate



4. Check that surface of swash plate is smooth and without any large scratches (depth more than 0.1 mm).

Pistons



5. Play in ball and socket joint must not exceed 0.1 mm.  
6. Thickness of piston shoes must be at least 4.4 mm.



7. Hold a ruler against surfaces of piston shoes to check that the surfaces are even and smooth and without any scratches. It is acceptable that the (black) treated surfaces of the pistons are partly worn.

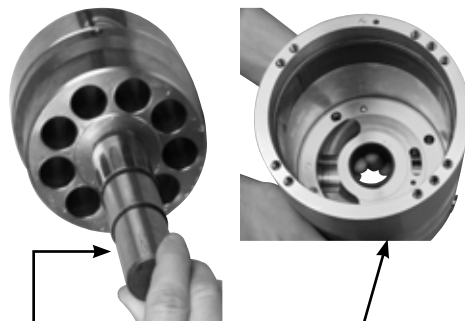

8. Check bushes in cylinder barrel for wear and scratches.  
9. Check main bearing for wear and scratches.

4. Assembly

**WARNING:**  
Do not use silicone when assembling the pump. Do not reuse disassembled O-rings; they might be damaged. Always use new O-rings.

**Important:**  
It is essential that the pump is serviced in conditions of absolute cleanliness. All parts must be absolute clean before mounting.



1. Lubrication:
- To prevent seizing-up, lubricate all threads with PTFE lubrication type.
  - O-rings inside pump may be lubricated only with clean filtered water.
  - O-rings for port flange, mounting flange and flushing valve must be lubricated.
  - It is important to lubricate ALL parts to be assembled with clean filtered water (Especially all PEEK parts).



1. Tools required for assembly of the pump.

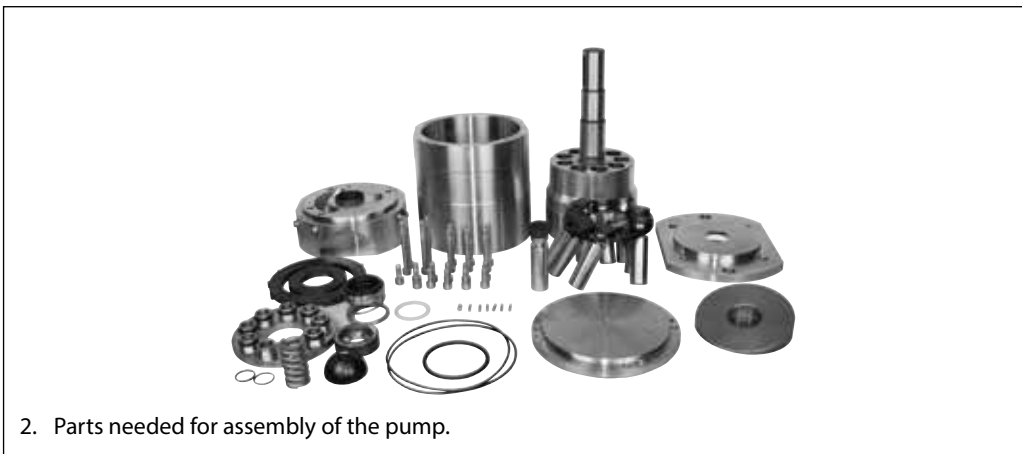

2. Parts needed for assembly of the pump.



3. Mount 1 guide pin in housing.

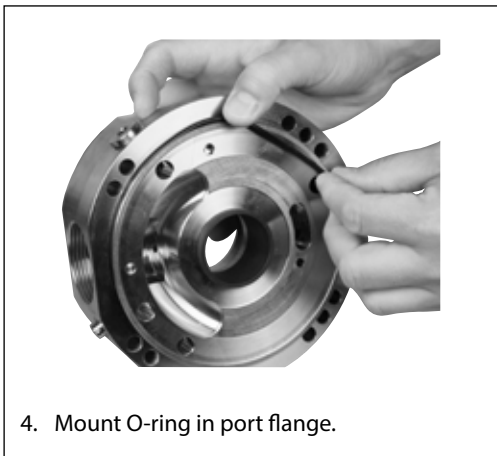

4. Mount O-ring in port flange.



5. Mount port flange on housing. Use pin as guide.



6. Mount 6 screws (M8x55).



7. Tighten screws to 30Nm.



8. Turn pump upside down.



9. Mount 1 guide pin inside the housing on the back side of the port plate.



10. Mount port plate. Be aware of orientation/guide pin.

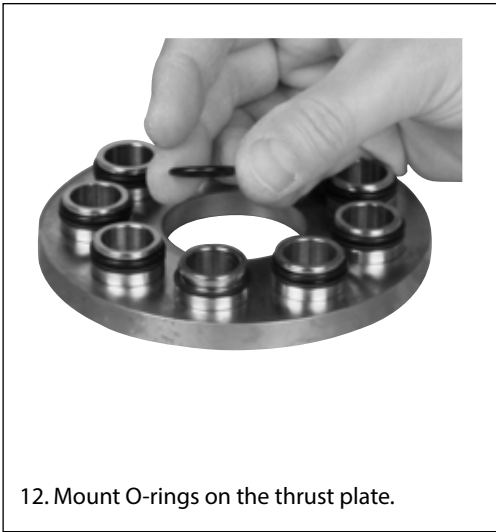

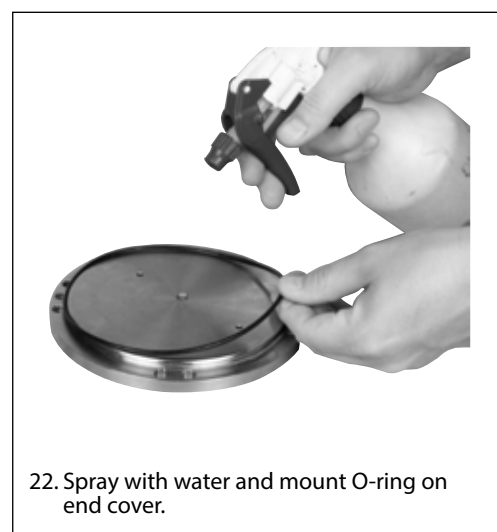

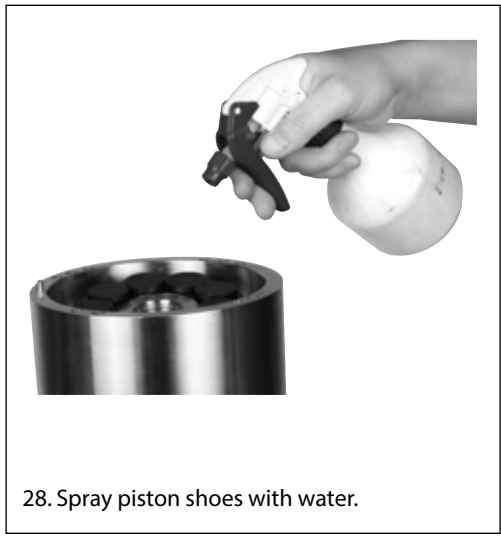
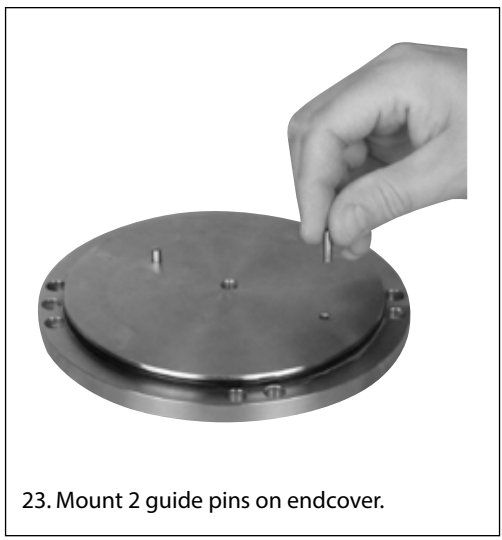





29. Mount endcover on the housing.



30. Mount 10 screws (M8x20).



31. Tighten 10 screws to 30Nm.



32. Turn pump upside down and mount 2 guide pins.



33. Spray with water and mount O-ring.

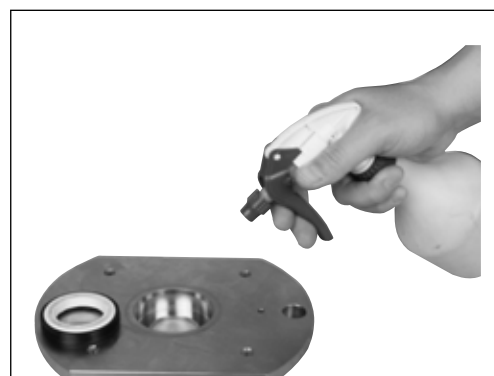

34. Spray shaft sealing with water before mounting.

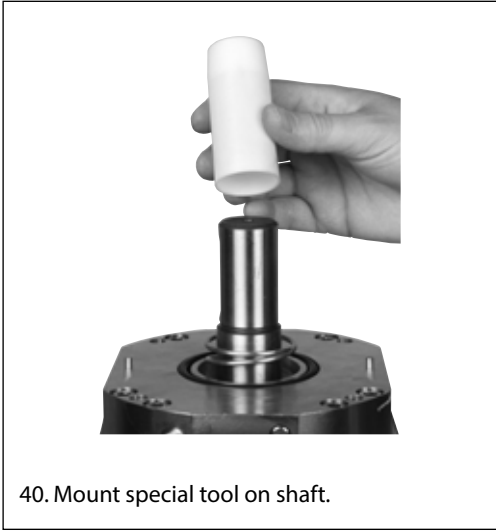
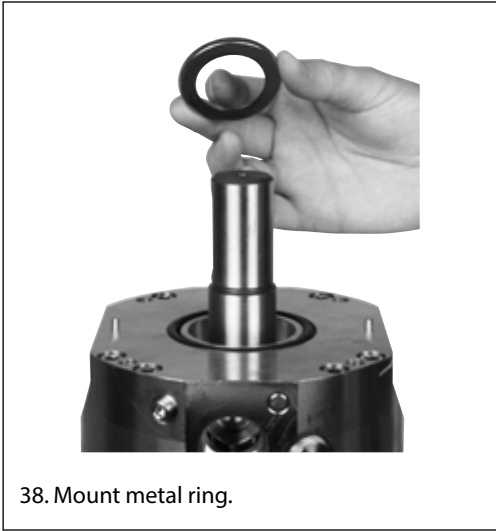
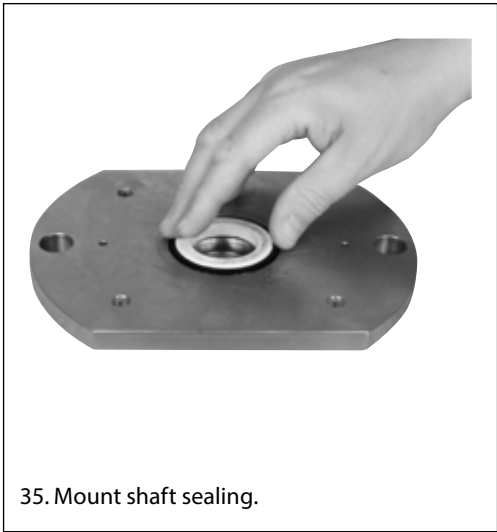

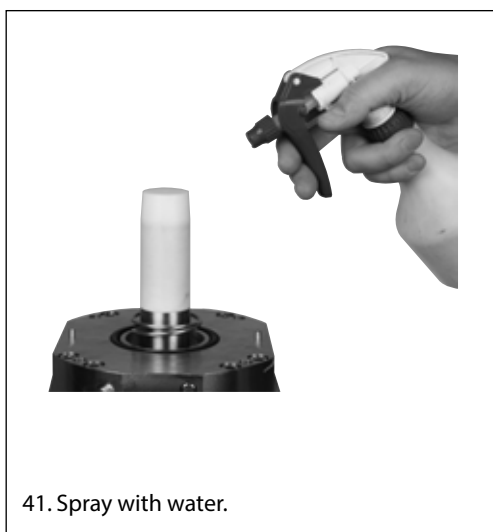

**5. Spare parts list for PAHT 50-90**

Pos.	Qty.	Designation	Material	180B4196 - Seal set (PAHT 50-90)	180B4195 - Cylinder barrel set (PAHT 50-90)	180B4192 - Valve plate set (PAHT 50-70)	180B4193 - Valve plate set (PAHT 80-90)	180B4194 - Piston set (PAHT 50-90)	180B4252 - Swash plate set (PAHT 50)	180B4255 - Swash plate set (PAHT 63)	180B4258 - Swash plate set (PAHT 70)	180B4253 - Swash plate set (PAHT 80)	180B4256 - Swash plate set (PAHT 90)
1	1	Housing	AISI 316										
2	2	Pin $\varnothing 4 \times 14$	AISI 304	x									
5	10	Screw M8 x 16	AISI 304	x									
9	1	O-ring $\varnothing 135 \times 3$	NBR	x									
11	1	End cover CW	AISI 316										
31	1	Swash plate	AISI 431						x	x	x	x	x
32	1	Screw M8 x 20	AISI 304						x	x	x	x	x
34	2	Pin $\varnothing 4 \times 14$	AISI 304						x	x	x	x	x
61	1	Cylinder barrel	AISI 431		x								
62	1	Spring	1.4462					x					
64	1	Retainer ball	AISI 431					x					
65	1	Retainer plate	AISI 304					x					
66	9	Piston	AISI 431/ PEEK					x					
67	1	Key 8 x 7 x 32	AISI 316Ti	x									
70	1	Washer	Polypropylen	x									
71	1	Retainer	AISI 304 / PEEK					x					
91	1	Port plate	AISI 304 / PEEK			x	x						
92	1	Valve plate	AISI 431			x	x						
93	9	Back up ring	PTFE			x	x						
94	9	O-ring $\varnothing 18,3 \times 2,4$	NBR			x	x						
121	1	Port flange	AISI 316										
122	1	O-ring $\varnothing 135 \times 3$	NBR	x									
123	1	O-ring $\varnothing 65 \times 5$	NBR	x									
124	1	Shaft sealing	AISI 304 / NBR	x									
125	1	End cover	AISI 316										
126	1	Pin $\varnothing 6 \times 10$	AISI 304			x	x						
127	6	Screw M8 x 70	AISI 304	x									
128	4	Screw M8 x 55	AISI 304	x									
	1	Service instruction		x	x	x	x	x	x	x	x	x	x

**Instruction**
**Disassembling and assembling PAHT and PAHT G 50-90**

6. Spare parts list for PAHT G 50-90				180B4341 - Seal set (PAHT G 50-90)	180B4339 - Cylinder barrel set (PAHT G 50-90)	180B4340 - Valve plate set (PAHT G 50-70)	180B4344 - Valve plate set (PAHT G 80-90)	180B4343 - Piston set (PAHT G 50-90)	180B4326 - Swash plate set (PAHT G 50)	180B4327 - Swash plate set (PAHT G 63)	180B4328 - Swash plate set (PAHT G 70)	180B4329 - Swash plate set (PAHT G 80)	180B4330 - Swash plate set (PAHT G 90)
Pos.	Qty.	Designation	Material										
1	1	Housing	AISI 316										
2	2	Pin ø4 x 14	AISI 304	x									
5	10	Screw M8 x 16	AISI 304	x									
9	1	O-ring ø135 x 3	NBR	x									
11	1	End cover CW	AISI 316										
31	1	Swash plate	AISI 431						x	x	x	x	x
32	1	Screw M8 x 20	AISI 304						x	x	x	x	x
34	2	Pin ø4 x 14	AISI 304						x	x	x	x	x
61	1	Cylinder barrel	AISI 431		x								
62	1	Spring	1.4462					x					
64	1	Retainer ball	AISI 431					x					
65	1	Retainer plate	AISI 304					x					
66	9	Piston	AISI 431 / PEEK					x					
67	1	Key 8 x 7 x 32	AISI 316Ti	x									
70	1	Washer	Polypropylen	x									
71	1	Retainer	AISI 304 / PEEK					x					
91	1	Port plate	AISI 304 / PEEK			x	x						
92	1	Valve plate	AISI 431			x	x						
93	9	Back up ring	PTFE			x	x						
94	9	O-ring ø18,3 x 2,4	NBR			x	x						
121	1	Port flange	AISI 316										
122	1	O-ring ø135 x 3	NBR	x									
123	1	O-ring ø65 x 5	NBR	x									
124	1	Shaft sealing	AISI 304 / NBR	x									
125	1	End cover	AISI 316										
126	1	Pin ø6 x 10	AISI 304			x	x						
127	6	Screw M8 x 70	AISI 304	x									
128	4	Screw M8 x 55	AISI 304	x									
	1	Service instruction		x	x	x	x	x	x	x	x	x	x

**9. Tool sets**

Qty.	Designation	180Z0237 - Tool set (PAH / PAHT / PAHT G 50-90)
1	Shaft bush, topedo	x
1	Press tool 1	x
1	Press tool 2	x

**Danfoss A/S**

High Pressure Pumps  
DK-6430 Nordborg  
Denmark

Danfoss can accept no responsibility for possible errors in catalogues, brochures and other printed material. Danfoss reserves the right to alter its products without notice. This also applies to products already on order provided that such alterations can be made without subsequential changes being necessary in specifications already agreed.  
All trademarks in this material are property of the respective companies. Danfoss and the Danfoss logotype are trademarks of Danfoss A/S. All rights reserved.